

W0.5

Ultra-compact two-way trapezoid system

features

- ▶ Ultra-compact trapezoid enclosure
- ▶ High SPL output capability
- ▶ 70° coverage angle
- ▶ Multi-laminate birch plywood construction
- ▶ 8" (200mm) LF/1" (25mm) HF driver combination

applications

- ▶ Audio-visual presentations
- ▶ Distributed sound systems
- ▶ Foreground and background music systems
- ▶ Live sound infill system



The Martin W0.5 Wavefront system is a miniature high performance loudspeaker designed to suit a variety of applications - from foreground systems in restaurants and bars to live sound infills in concert situations.

It is a passive two-way system featuring an 8" (200mm) high power bass driver and a 1" (25mm) ferrofluid cooled compression driver on a 70° x 50° constant directivity horn. The drive units are housed in a rugged plywood enclosure built using the same techniques as larger Martin touring systems. Its two-way passive configuration simplifies operation, ensures predictable performance and reduces amplifier count.

The 70° medium Q horizontal coverage angle of the W0.5 allows it to be used either as a portable stand alone system, as a component in a distributed sound system or coupled with other W0.5's to form a wider dispersion array.

Optimum performance of the W0.5 is achieved when it is used with a system controller which provides low frequency equalisation and limiter functions. Because the W0.5 is a passive full-range system embodying acoustically correct design principles, it may also be used without a controller - provided recommended amplifier power is not exceeded and care is taken to avoid amplifier clipping and excessive low frequencies below 70Hz.

For applications where ultra-low frequency enhancement is required, a Wavefront Series sub-bass system can be used in conjunction with the W0.5 and a system controller to extend the bandwidth of the system to below 35Hz.

To simplify installation, threaded steel inserts are fitted into the enclosure for the fixing of rigging hardware. A perforated steel grille protects the drive units and a single rear handle allows the W0.5 to be carried with one hand. A tripod mount is also fitted to the base of the enclosure.

Century Point, Halifax Road, Cressex Business Park,
High Wycombe, Buckinghamshire HP12 3SL, England.
Telephone: +44 (0)1494 535312 Facsimile: +44 (0)1494 438669
E-mail: info@martin-audio.com
All information is Copyright © 2006 Martin Audio Ltd.



W0.5

Ultra-compact two-way trapezoid system

overall dimensions

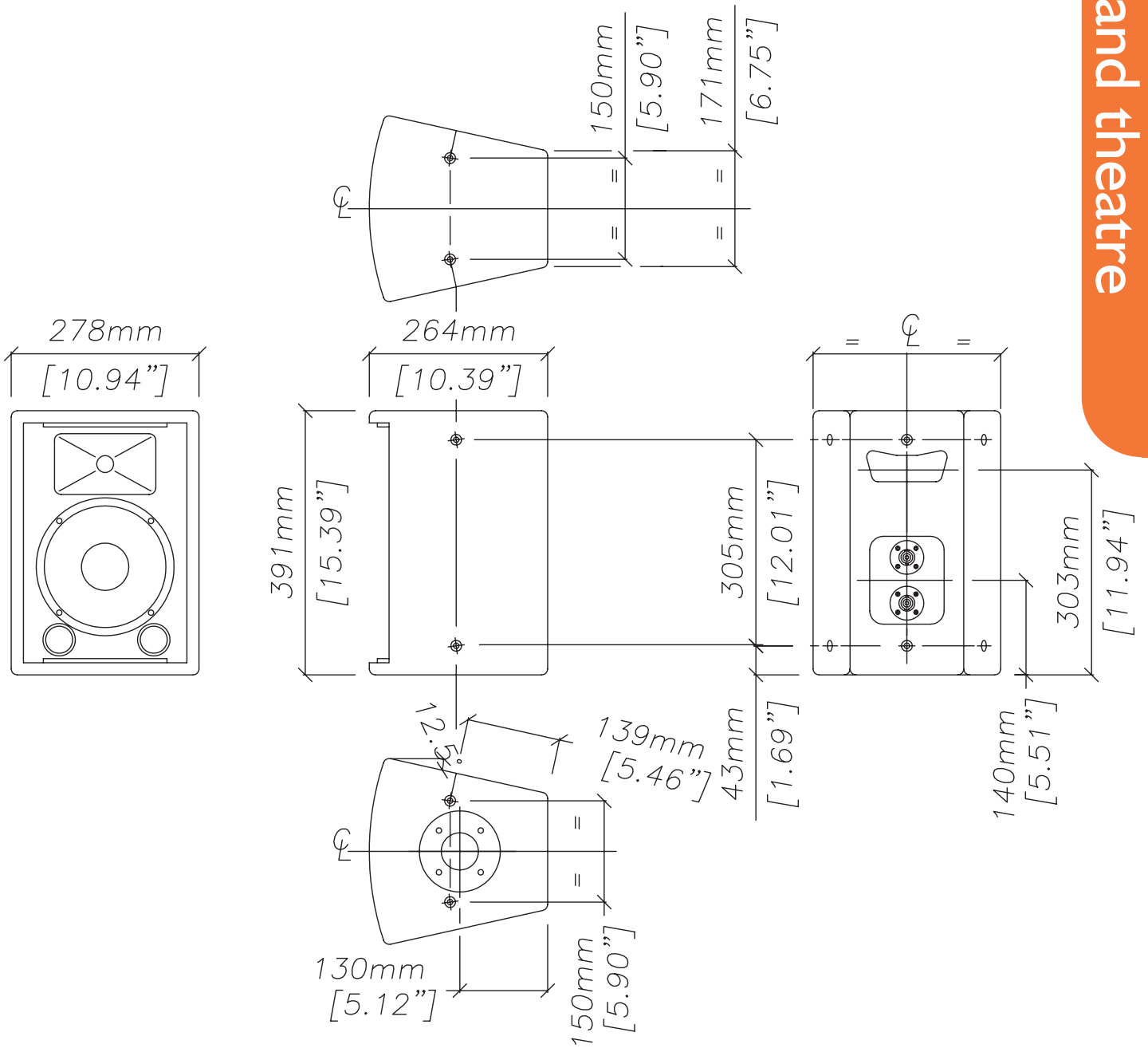

W0.5

Century Point, Halifax Road, Cressex Business Park,
High Wycombe, Buckinghamshire HP12 3SL, England.
Telephone: +44 (0)1494 535312 Facsimile: +44 (0)1494 438669
E-mail: info@martin-audio.com
All information is Copyright © 2006 Martin Audio Ltd.



touring and theatre

W0.5

Ultra-compact two-way trapezoid system

technical specifications

TYPE	Ultra-compact two-way passive trapezoid
FREQUENCY RESPONSE (5)	70Hz-18kHz \pm 3dB -10dB @ 50Hz
DRIVERS	8" (200mm) bass driver 1" (25mm) exit HF compression driver
RATED POWER (2)	125W AES, 500W peak
RECOMMENDED AMPLIFIER	300-400W into 4 ohms
SENSITIVITY (6)	94dB
MAXIMUM SPL (7)	114dB continuous, 120dB peak
NOMINAL IMPEDANCE	8 ohms
DISPERSION (-6dB)	70° horizontal, 50° vertical
CROSSOVER	3kHz passive
FINISH	Textured grey paint
PROTECTIVE GRILLE	Grey perforated steel
CONNECTORS	2 x Neutrik NL4
FITTINGS	10 x M8 threaded inserts 1 x mounting pole socket
DIMENSIONS	(W) 278mm x (H) 391mm x (D) 264mm (W) 10.9ins x (H) 15.4ins x (D) 10.4ins
WEIGHT	10kg (22lbs)

accessories

HTKCT05 8mm Shouldered eye bolt

Notes

- (1) Measured on-axis in half space at 2 metres, then referred to 1 metre.
- (2) AES Standard ANSI S4.26-1984.
- (3) Measured in half space at 2 metres with 1 watt input, using band limited pink noise, then referred to 1 metre.
- (4) Measured in half space at 2 metres using band limited pink noise, then referred to 1 metre.
- (5) Measured on-axis in open (4π) space at 2 metres, then referred to 1 metre.
- (6) Measured in open (4π) space at 2 metres with 1 watt input, using band limited pink noise, then referred to 1 metre.
- (7) Measured in open (4π) space at 2 metres using band limited pink noise, then referred to 1 metre.

Trade Descriptions Act

Due to Martin Audio's policy of continuing improvement, we reserve the right to alter these specifications without prior notice. Martin Audio is committed to refining state of the art sound reinforcement, combining in-depth product and field applications research with advanced manufacturing techniques. Every Martin Audio product is built to the highest manufacturing standards and rigorously tested to ensure that it meets the performance criteria specified in the design.

architectural and engineering specifications

The loudspeaker system shall be of the two-way passive type consisting of one 8" (200mm) direct radiating reflex loaded low frequency transducer and one 1" (25mm) ferrofluid cooled high frequency driver mounted in a trapezoidal plywood enclosure. The enclosure shall be fitted with an integral pole mounting socket and threaded inserts for wall and ceiling mounting. Low and high frequency sections shall be integrated by an internal 3kHz passive crossover network.

Performance of the loudspeaker system with its electronic controller shall meet or exceed the following criteria:

Frequency response measured 1 metre on axis shall be 70Hz-18kHz \pm 3dB.

High frequency dispersion at -6dB points shall be 70° H x 50° V.

Power handling shall be 125W AES, 500W peak.

Rated impedance shall be 8 ohms.

Maximum SPL measured at 1 metre on axis shall be 114dB continuous, 120dB peak.

Dimensions (W) 278mm x (H) 391mm x v264mm (10.9ins x 15.4ins x 10.4ins).

Weight 10kg (22lbs).

The loudspeaker system shall be the Martin Audio W0.5.

Century Point, Halifax Road, Cressex Business Park,
High Wycombe, Buckinghamshire HP12 3SL, England.
Telephone: +44 (0)1494 535312 Facsimile: +44 (0)1494 438669
E-mail: info@martin-audio.com
All information is Copyright © 2006 Martin Audio Ltd.

